

Solar monitoring

Product Manual

VSN800 Weather Station



VSN800 Weather Station

This manual covers the details for installing the VSN800 Weather Station hardware to sense environmental variables. Through the VSN800 Weather Station, the Aurora Vision Plant Management Platform can collect and analyze environmental data for comparison to predicted environmental data and actual inverter/solar panel output.

The RS485 port of the VSN800 Weather Station is attached via low-voltage wires to the monitoring or management system and communicates information to the management system using the Modbus protocol. The weather station is powered via 24VDC power, which is typically available from the data collection hardware of the management system.

Once the hardware is installed, you will need to login to the management system website to verify the Internet is connected properly and verify that the data is being received.

The VSN800 Weather Station is SunSpec compliant and uses a 2-wire half duplex serial port for Modbus communication to a host. Contact ABB if you need to modify or program the unit or change the Modbus address.

VSN800 series installation overview

VSN800-14

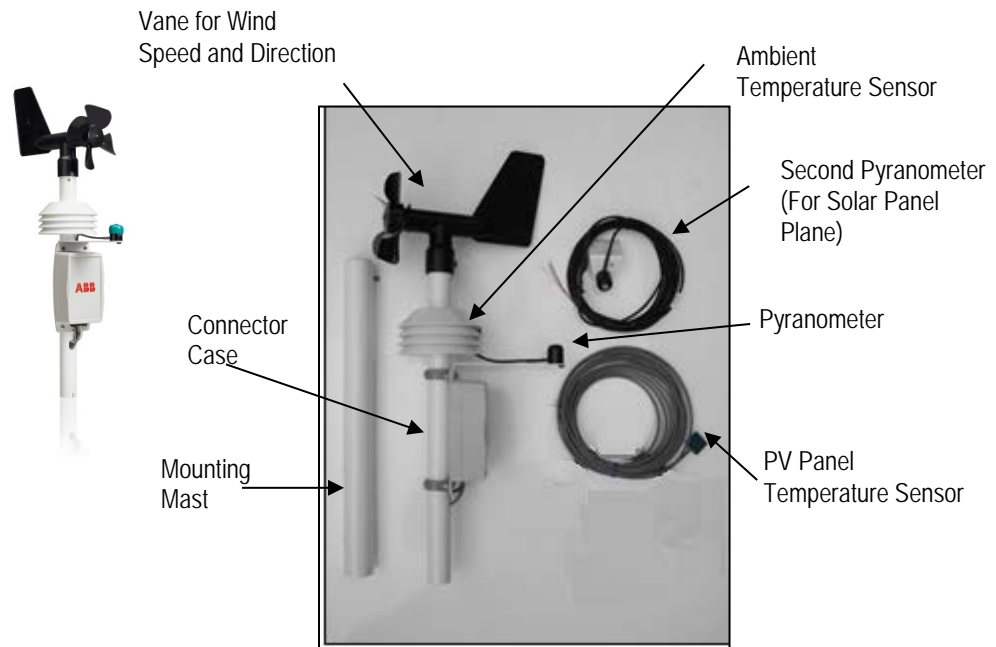

VSN800-12

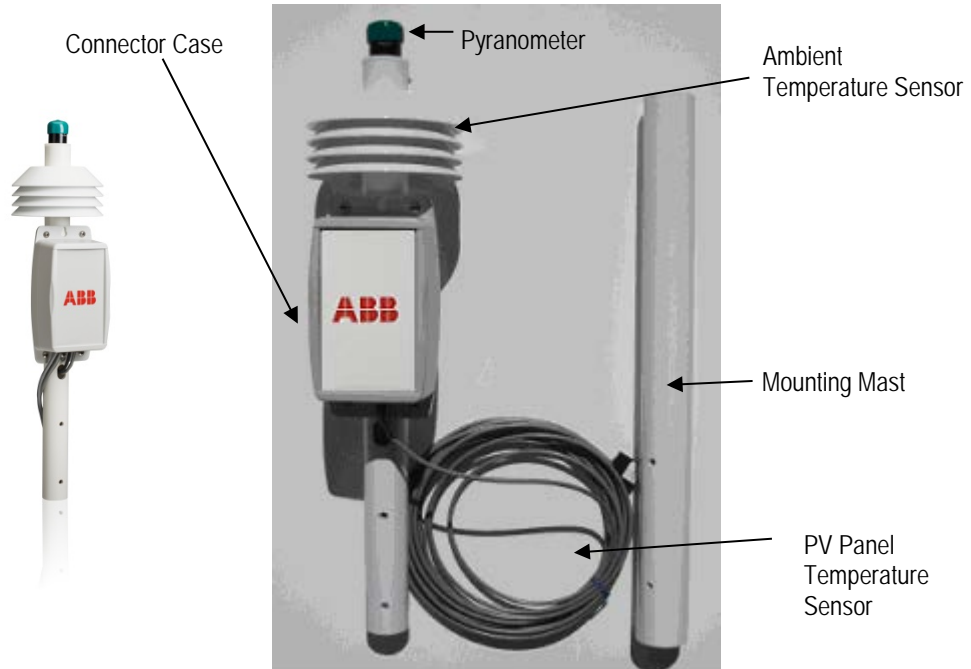

Installation steps

- 1 Select Location for the VSN800
- 2 Make Connections to 24VDC Power
- 3 Make Connections to Management System through RS485
- 4 Install PV Panel Temperature Sensor;
For the VSN800-14 Model, Install Secondary Pyranometer
- 5 Complete Mounting of the VSN800
- 6 Verify and validate the Installation via the Management System

Equipment and supplies

We supply:	You supply:
VSN800 Weather Station, which includes: Pyranometer Ambient Temperature Sensor External PV Panel Temperature Sensor External Second Pyranometer (VSN800-14 Model Only) Wind Speed and Wind Direction Sensor (VSN800-14 Model Only)	Mounting Hardware Tripod or pole mount base Guy wire kit, if necessary 24VDC Power Twisted Pair Wires

Site selection and mounting

Weather station location

The ideal site is level and well away from obstructions such as buildings, trees, and steep slopes. The weather station is typically pole or tripod mounted.

Take into account the needs for all attached sensors to determine the optimal mounting location. Ambient air temperature and irradiance measurements can be affected by obstructions, local topography, and surface type. Each site is different and presents unique challenges. By far the most important consideration is obstruction.

- Objects that are 10 degrees or more above the horizontal plane must not block irradiance.
- Ambient air temperature measurement should be placed away from any dark, heat-absorbing surface (asphalt, dark-colored surfaces) and should be no closer than 4 times the obstruction's height.

A simple way to think of obstruction is the rule of 10. If the obstruction is at a distance of at least 10 times its height above the weather station, you're good.

Towers can be used to raise the weather station above low-lying obstructions.

Weather station mounting requirements

Mount the support mast securely to a support structure. Mounting equipment is sold as an accessory. The mast may also be attached to a support structure using U-Bolts. Do not tighten the support structure to the unit, as directional orientation will be required.

Rotate the assembled unit until the electronics enclosure faces TRUE SOUTH or TRUE NORTH if you are in the northern or southern hemisphere, respectively. Secure the support mast to the assembly. Lining up the two holes in each mast prevents rotation. At this point the entire unit should be secured to the support structure.

It is crucial that the device be oriented as precisely as possible. For the VSN800-14 version, the wind direction measurement is directly related to this positioning.

Regardless of how you mount the system, the bottom of the electronic enclosure should not extend more than 12" or less than 7" above the support of the mounting tube.



Other Mounting Considerations

The exact method of mounting the weather station is left to the installer. However, there are some guidelines and recommendations to consider.

- The environmental unit is designed to withstand very harsh weather conditions. Refer to the data for individual sensors for the ranges at which measurements remain accurate.
- The environmental unit weighs approximately 7 lbs. Pole mounts in the ground or attached to structures that support up to 50 lbs. are recommended.

- For ground tripod mounts, the ground should be as level as possible.
- For roof mounts, avoid locating the station near any heat sources such as chimneys or vents. Do not install on an existing mast unless you know the mast can take the additional weight of the weather station. When roof-mounting the sensor assembly, the unit should be mounted toward an edge of the roof preferably on the prevailing wind side of the building and should be at least 2-1/2 feet above the roofline.
- The weather station unit should be mounted at least 5 feet off the ground. Surrounding terrain and structures may dictate a much higher mount.
- If the weather station is mounted more than 10 feet off the ground, guy wires should be used to secure the mount. Guy wire attachments must not interfere with instruments.
- Wall-mounting, pole-mounting, or tripod kits are available. Contact your ABB distributor.
- Test the system at ground level and make sure it operates properly prior to final mounting.

Sensor mounting requirements

Global Irradiance

The pyranometer is attached to the sensor assembly and is oriented to measure global irradiance. To accurately measure this quantity the sensor must be level, orientated either TRUE SOUTH or TRUE NORTH if you are in the northern or southern hemisphere, respectively, and objects above 10° above the horizontal plane must not block the sensor.

Be sure to remove the protective green cap from all pyranometers so they can measure insolation.

Plane-of-Array Irradiance (VSN800-14 Model Only)

The plane-of array pyranometer is mounted on the side of the solar array. The sensor should be at the same zenith and azimuth angle as solar array to correctly measure the plane-of-array irradiance.

Anemometer (VSN800-14 Model Only)

The anemometer is directly attached to the top of the sensor assembly. For correct wind direction operation the VSN800-14 must be oriented correctly.

By default the weather station is configured for operation in the Northern hemisphere. This requires that the irradiance sensor faces due south. If the weather station is going to be used in the Southern hemisphere it must be mounted with the irradiance sensor facing north. In addition, the hemisphere jumper inside the VSN800-14 must be changed from Northern to Southern.

PV Temperature Sensor

This sensor is designed to attach directly to any solar panel. When placed on the center back side of the panel, it accurately measures the temperature of the panel.

Prior to installation of the PV temperature sensor onto the PV panel, the installation area of the panel back should be thoroughly cleaned. This cleaning will ensure a good bond between sensor and panel and allow for accurate panel temperature readings.

After cleaning, peel off the protective adhesive tape on the temperature sensor and stick it onto the back of the panel. Firmly press the sensor into place. Refer to the picture on the right. The cable should be secured within 8 inches of the temperature-sensing element.



Run the cable back to the weather station unit and connect to the PV temperature sensor terminals.

If the cable length is insufficient for the installation, additional cable can be added to the existing cable. If this is done, an accuracy derating factor must be added to the overall temperature accuracy of this sensor. For every 100ft of cable added, an accuracy derating factor of -0.125°C must be taken into account.

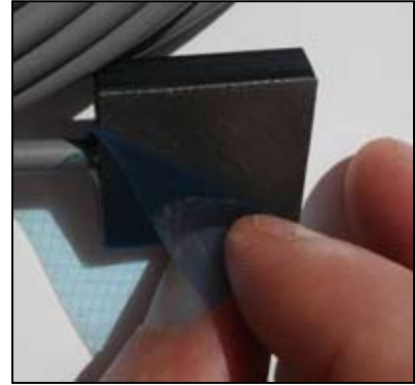

Cabling requirements to management system

The maximum cable distance between weather station and the SunSpec-compliant management system is 1000 m (3000 ft.).

High-voltage areas of power plants are “electrically noisy” environments so shielded cable is advised for connection from the weather station to RS485. If outdoor exposure or proximity to a noise source is a concern, Beldon 1120A or equivalent cabling should be used.

Cables to external sensors are supplied with the sensor.

Wiring instructions for the VSN800 series

Supply 24VDC Power

1. Run wire from the 24VDC power source to the weather station.
2. Find the back of the connection case on the weather station. Unscrew the four retaining screws at the corners with a Philips screwdriver. See the figure below.

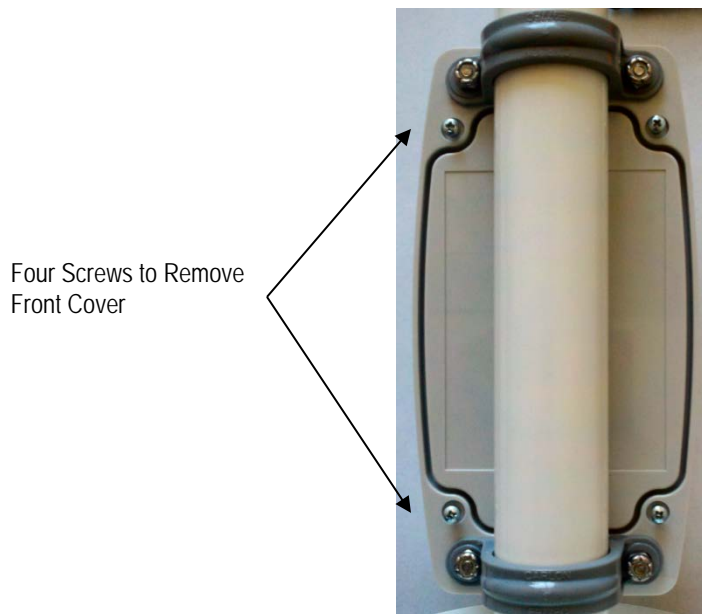

Weather Station Connection Case (Back View)

- Flip the unit over and remove the cover. Find the 24VDC power connectors on the electronics board in the case. Connect power to the 3-pin screw terminal inside the connection case.

The power supply is nominally rated for 24VDC but can accept a voltage in the range of 10 to 30VDC. The inputs are reverse polarity, surge, over-voltage, and over-current protected. The power supply is not isolated.

Power Supply Terminals

Earth Gnd:	Earth or Chassis Ground
Gnd:	Negative Supply Voltage
24VDC	Positive Supply Voltage

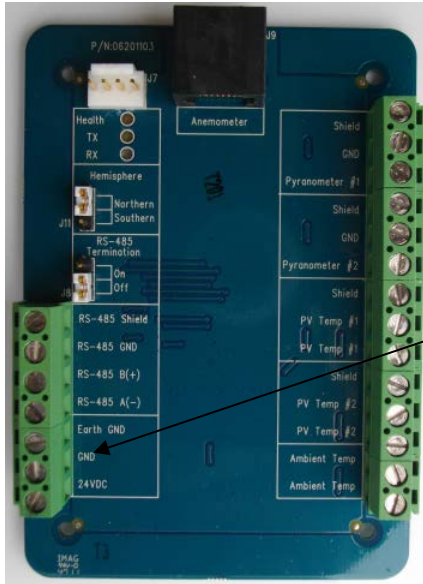

VSN800-14



VSN800-12

24VDC Connectors:
Earth GND
GND
24VDC Power

Weather Station Electronics Board

- Leave the case open to install the other wires as described in the next section.

Southern hemisphere adjustment

For the VSN800-14 model, if you are in the southern hemisphere, the jumper at J11 must be set to Southern. If you are in the northern hemisphere, no adjustment is required. J11 is located in the upper left section of the circuit board.

Connect to the monitoring or management system

The Modbus (RS485) connection is same as with any other RS485 device connected to a SunSpec-compliant management system. Refer to your management system documentation of any unique installation requirements.

- String cable between the weather station and the management system to complete the physical connection. The connection to the management system can be as a single RS485 device or as part of a daisy chain of RS485 devices. Cable is not supplied with the unit. Use twisted pair wire for connections.
- Wiring connections are made using the 3-pin screw terminal inside the connection case. See the figure below.

3. The RS485 line must be terminated with a 120-ohm resistor. If the device is the only device in the chain or at the end of the chain, you must set the jumper (J8) to terminate the RS485 line. The factory setting for RS485 line termination is OFF.
4. Placement can be other than the end of the chain if the RS485 termination is disabled. To locate the device in the middle of a daisy chain, set the jumper at location J8 between the pins **Common** and **Off** to disable RS485 termination.

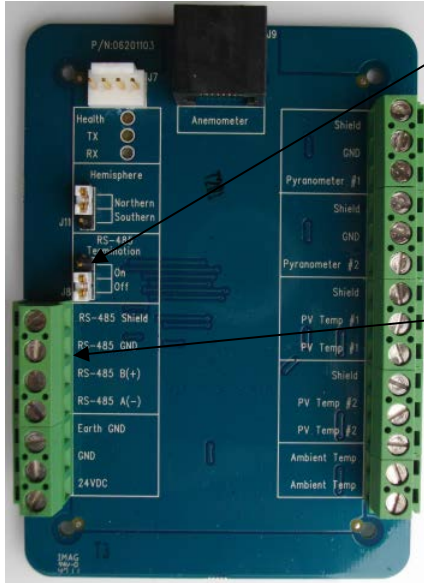

VSN800-14

Jumper J8:
 Jumper Common to On:
 RS485 Termination
 Jumper Common to Off:
 No RS485 Termination

RS485 Connectors:
 RS-485 A (-)
 RS-485 B (+)
 RS-485 GND
 RS-485 Shield

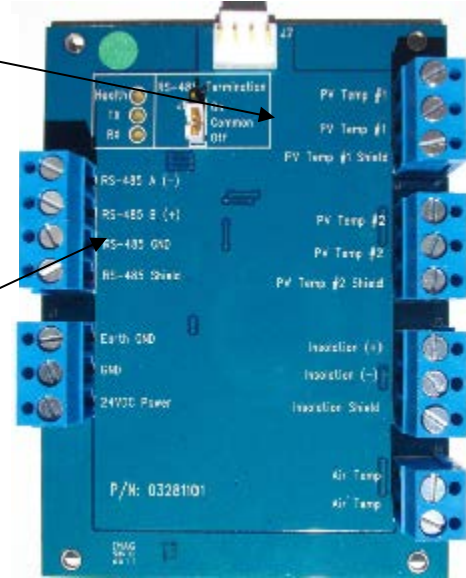

VSN800-12

Weather Station Electronics Board, Jumper for RS485 Termination

The default address of the weather station is 60. Contact Customer Support if it is required to change the address. You cannot have two weather stations in the same RS 485 chain unless the address of one of the weather stations is changed.

RS485 Terminals

Terminal Label	RS485 Signal
RS485 A (-)	Negative RS485
RS485 B (+)	Positive RS485
GND:	Signal Ground
RS-485 Shield	Shield Ground

SunSpec and Modbus Communication Settings

Variable	Value
Default Modbus ID	60

SunSpec register map

Start	End	#	Name	Type	Units	Scale Factor	Constants	Description
0001	0002	2	C_SunSpec_ID	uint32	N/A	N/A	"SunS"	Well-known value. Uniquely identifies this as a SunSpec Modbus Map
0003	0003	1	C_SunSpec_DID	uint16	N/A	N/A	0x0001	Well-known value. Uniquely identifies this as a SunSpec Common Model block
0004	0004	1	C_SunSpec_Length	uint16	registers	N/A	65	Length of common model block
0005	0020	16	C-Manufacturer	String(32)	N/A	N/A	"ABB"	Well-known value
0021	0036	16	C-Model	String(32)	N/A	N/A	"VSN800-12" or "VSN800-14"	Manufacturer specific value
0037	0044	8	C-Options	String(16)	N/A	N/A	"0"	Manufacturer specific value
0045	0052	8	C-Version	String(16)	N/A	N/A	"1"	Manufacturer specific value
0053	0068	16	C_Serial Number	String(32)	N/A	N/A	"Serial"	Manufacturer specific value
0069	0069	1	C_DeviceAddress	uint16	N/A	N/A	60	Modbus Id
SunSpec Device Model Measurement Registers								
0070	0070	1	C_SunSpec_DID	int16	N/A	N/A	307	Start of next Device
0071	0071	1	C_SunSpec_Length	int16	N/A	N/A	11	Device Model Block Size
0072	0072	1	E_BaseMet_Air Temperature	int16	°C	-1	Measured	Ambient Air Temperature
0073	0073	1	E_BaseMet_Relative Humidity	int16	%	0	N/A	Relative Humidity
0074	0074	1	E_BaseMet_Barometric_Pressure	int16	Hpa	0	N/A	Barometric Pressure
0075	0075	1	E_BaseMet_Wind_Speed	int16	m/s	0	Measured	Wind Speed
0076	0076	1	E_BaseMet_Wind_Direction	int16	Degrees	0	Measured	Wind Direction
0077	0077	1	E_BaseMet_Rain	int16	Inches	0	N/A	Rainfall
0078	0078	1	E_BaseMet_Snow	int16	Inches	0	N/A	Snowfall since last poll
0079	0079	1	E_BaseMet_PPT_Type	int16	Inches	N/A	N/A	Precipitation Type (WMO 4680 SYNOP code reference)
0080	0080	1	E_BaseMet_Electric_Field	int16	V/m	0	N/A	Electric Field
0081	0081	1	E_BaseMet_Surface_Wetness	int16	kOhms	0	N/A	Surface Wetness
0082	0082	1	E_BaseMet_Soil_Moisture	int16	%	0	N/A	Soil Moisture

Start	End	#	Name	Type	Units	Scale Factor	Constants	Description
SunSpec Irradiance Model Registers								
0083	0083	1	C_SunSpec_DID	int16	N/A	0	302	Well-known value. Uniquely identifies this as a SunSpec Irradiance Model
0084	0084	1	C_Sunspec_Length	int16	N/A	0	5	Variable length model block $= (5 * n)$, where n=number of sensors blocks
0085	0085	1	E_Irradiance_Global_Horizontal_1	uint16	W/m ²	0	Measured	Global Horizontal Irradiance
0086	0086	1	E_Irradiance_Plane-of-Array_1	uint16	W/m ²	0	Measured	Plane-of-Array Irradiance
0087	0087	1	E_Irradiance_Diffuse_1	uint16	W/m ²	0	N/A	Diffuse Irradiance
0088	0088	1	E_Irradiance_Direct_1	uint16	W/m ²	0	N/A	Direct Irradiance
0089	0089	1	E_Irradiance_Other_1	uint16	W/m ²	0	N/A	Some other type Irradiance
SunSpec Back of Module Temperature Registers								
0090	0090	1	C_SunSpec_DID	int16	N/A	0	303	Well-known value. Uniquely identifies this as a SunSpec Back of Module Temperature Model
0091	0091	1	C_Sunspec_Length	int16	N/A	0	2	Variable length model block $= (5 * n)$, where n=number of sensors blocks
0092	0092	1	E_BOM_Temp_1	int16	°C	-1	Measured	Back of module temperature
0093	0093	1	E_BOM_Temp_2	int16	°C	-1	Measured	Back of module temperature
End of Block Registers								
0094	0094	1	EndOfSunSpecBlock	uint16	N/A	N/A	0xFFFF	End of SunSpec Block
0095	0095	1	C_Sunspec_Length	uint16	N/A	0	0	Terminate length, zero
Device Address Write Register								
0200	0200	1	Modbus Id - Write Register	int16	N/A	N/A	60	Modbus device address, write register

Connect secondary sensors (VSN800-14 model only)

If you are not planning to connect the PV panel temperature sensor and the secondary Pyranometer, skip this section.

1. Attach the second Pyranometer to your array. The sensor should be attached so top of the sensor is in the same plane as the PV panels. The sensor comes pre-attached to a bracket for easy installation.
2. Attach the PV panel temperature sensor so it registers the temperature on the backside of a PV panel. See [Sensor Mounting Requirements](#) for location and mounting considerations.
3. Connect the sensor(s) to the proper location on the circuit board. Connect the Pyranometer cable to terminals **Pyranometer #2** and **GND**. Connect the PV Panel temperature sensor cable to the two terminals labeled **PV Temp #1**.

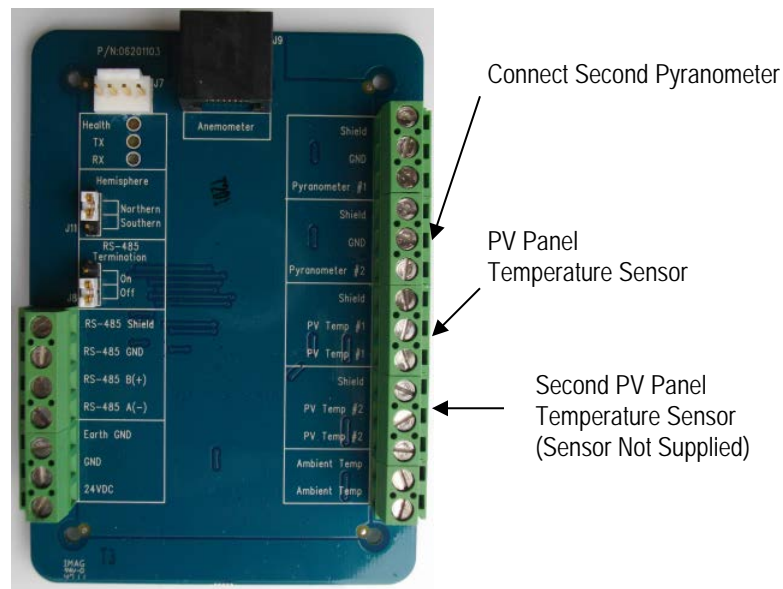

Weather Station Electronics Board, Connect Secondary Sensors (VSN800-14 Model)

The Pyranometer sensors are not interchangeable. The Pyranometer sensor supplied with the weather stations must be wired to Pyranometer #2.

The PV temperature sensor is not polarity sensitive. Therefore, each signal wire is interchangeable. The sensor comes with a 25ft length of cable. If the temperature sensor is not used, it should be terminated with a 0-ohm shunt between the positive and negative signal.

Plane-of-Array Sensor Terminals

Pyranometer #2:	Positive Signal (Red)
Ground:	Negative Signal (Black)
Shield:	Cable Shield and Drain (clear)

PV Temperature Terminal, 1st Sensor

PV Temp #1:	Signal (Black or White)
PV Temp #1:	Signal (Black or White)
Shield:	Cable Shield and Drain (bare)

Connect PV panel sensor (VSN800-12 only)

If you are not planning to connect the PV panel temperature sensor, skip this section.

1. Attach the PV panel temperature sensor so it registers the temperature on the backside of a PV panel. See [Sensor Mounting Requirements](#) for location and mounting considerations.
2. Connect the sensor to the proper location on the circuit board. Note that the PV Temp #2 connectors are not used for the VSN800-12 Model.

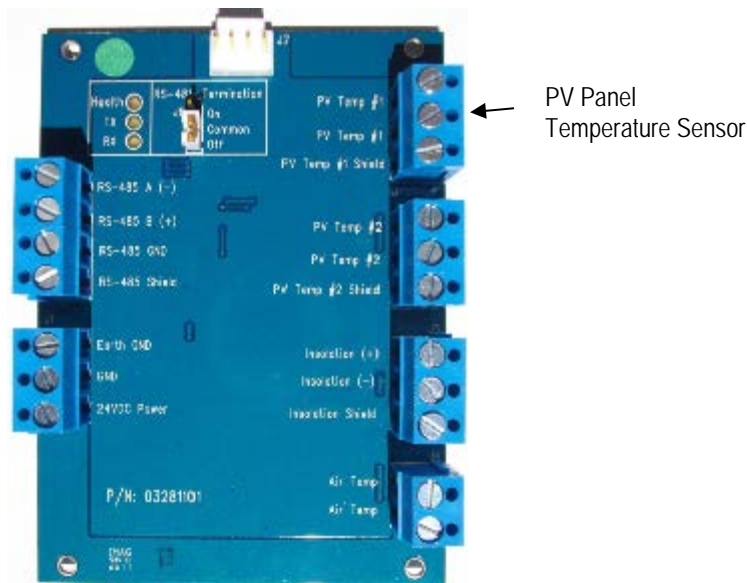

Connect PV Panel Sensor (VSN800-12 Model)

The PV panel temperature sensor is not polarity sensitive. Therefore, each signal wire is interchangeable. The sensor comes with a 25ft length of cable. If a temperature sensor is not used, it should be terminated with a 0-ohm shunt between the positive and negative signal.

PV Temperature Terminal, 1st Sensor

PV Temp #1:	Signal (Black or White)
PV Temp #1:	Signal (Black or White)
Shield:	Cable Shield and Drain (bare)

Complete the Installation

1. Properly ground the weather station by connecting the **Earth GND** terminal at the Weather Station to an earth ground. Connecting the **Earth GND** helps ensure the accuracy of weather instruments.
2. Re-attach the cover to the connection case using the four screws. Make sure not to pinch the newly connected 24VDC or RS485 wires coming out of the case bottom. Note that the cover only goes on one way with the opening for wires at the bottom.
3. If necessary, complete the pole mounting of the weather station.

Connections to VSN750 series products

This section shows how to tap the 24VDC power and make RS485 connections from a VSN750 series management system. Most other monitoring systems will have a means of supplying 24VDC power. Consult your monitoring system documentation for information.

1. After making the correct 24VDC and RS485 attachments to the weather station, run cable from the weather station to the VSN750. Note that connections for power can be made to the VSN750 or directly to another 24 VDC power supply
2. Connect the wires for the 24VDC power and RS485 to the VSN750. See the figure below. Note that some VSN750 models may have RS485 connection points in other locations.

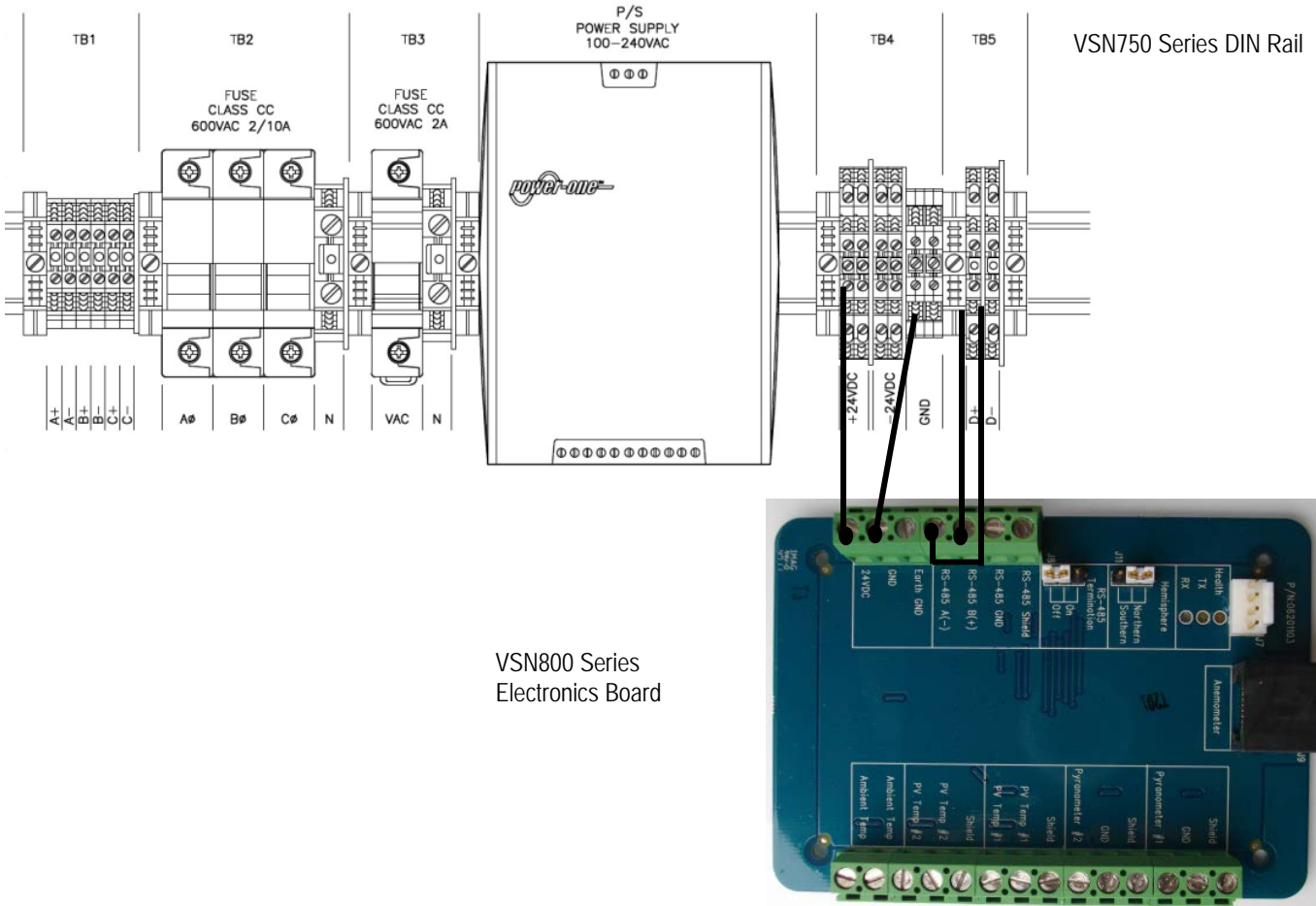

Weather Station Connection to VSN750 Series

System activation and validation

If you acquired the VSN800 series as part of a product bundle, please refer to the information that came with your VSN750 series package. This information will describe the next steps for product installation and system validation.

The management system must be properly installed and communicating before you can verify that data is flowing from the VSN800 series weather station.

If you are using VSN800 series in conjunction with Plant Portfolio Manager software, go to www.auroravision.net and log in to Plant Portfolio Manager with your account name and password. Using your product license key, set up the connection to the VSN800 series weather station.

Specifications

Material Specifications

Sensor Assembly:

RoHS Compliant

Mast:	Polyvinyl Chloride
Heat Shields:	Acrylonitrile Butadiene Styrene
Insulation Sensor Bracket:	Delrin
Hardware:	Stainless Steel and Nylon Locknut
Foam Gasket:	Vinyl and Acrylic

Enclosure:

RoHS Compliant

IP65 Rated Outdoor Enclosures

UL 94 V-2

Polycarbonate Body

Pyranometer Sensor:

RoHS Compliant

Body:	Anodized Aluminum with Cast Acrylic Lens
Cable:	Santoprene Jacket

Ambient Air Temperature Sensor:

RoHS Compliant

PV Panel Temperature Sensors:

RoHS Compliant

Body:	Anodized Aluminum
Adhesive Tape:	Acrylic, Titanium Diboride, and Aluminum
Cable:	Polyvinyl Chloride Jacket

Power and Communications Cable:

Cable:	Polyvinyl Chloride
--------	--------------------

Physical:

Packaged Weight:	7 lbs.
Packaged Dimensions:	6cm x 20.3cm x 20.3cm (10.25" x 8" x 8")

Electronics:

RoHS Compliant

Hardware Specifications

Power Specifications:

Power Requirements: 10 to 30VDC at 50mA

Operating Environment:

Temperature: -40°C to 60°C (-40 to 140°F)

Humidity: 0-100% Condensing

Pyranometer Sensors:

Range: 0 to 1750 W/m²

Accuracy: +/-5%

Cosine Response 45° +/-1%

Cosine Response 75° +/-5%

Operational Temperature: -25 to 55°C (-13 to 131°F)

Ambient Air Temperature Sensor:

Range: -40° to 80°C (-40 to 176°F)

Accuracy: +/- 0.3°C (0.54°F)

Thermal Time Constant 30 sec.

PV Panel Temperature Sensor:

Range: -40° to 80°C (-40 to 176°F)

Accuracy: +/- 0.3°C (0.54°F)

Thermal Time Constant: 270 sec.

Cable Length 7.62m (25 ft.)

Anemometer:

Operational Temperature: -40 to 60°C (-40 to 140°F)

Speed

Range: 0 – 67 meters per second (150 mph)

Accuracy: Greater of 0.45m/sec. (1 mph) or 5%

Threshold: 0.89m/sec. (2 mph)

Direction

Range: 360°

Resolution: 22.5°

Accuracy: +/- 22.5°

Threshold: 0.9 m/sec. (2 mph) at a 10° deflection.

RS-485/422 Serial Specifications:

Mode: 2-wire half duplex

Connector: 4-position screw terminal

Max Speed: 19200 bps

Max. Modbus Poll Rate: 100 ms

Termination: 120 ohms (internal jumper enable)

Contact us

www.abb.com/solar